

## ► Information Management System

The Information Management System (IMS) is a ship-borne network, based on SAFENET, that manages the transfer of time-critical command and control messages, multimedia streams and background file transfer from many sources to many destinations. The IMS architecture supports unicast, broadcast and reliable multicast data transfer types. It also provides for network synchronisation and message timestamping as well as sophisticated built-in test and network management.

The IMS offers bounded packet latencies, message-level prioritisation, synchronous bandwidth allocation, high overall performance, determinism and reliability.

Apart from ship-borne applications, other typical applications are in real-time vetronics systems as well as tactical command and control systems.

### IMS Architecture

The C<sup>2</sup>I<sup>2</sup> Systems Information Management System (IMS) communications architecture follows the dissemination architecture designed for real-time communications, referred to in the *Dissemination Architecture* below. The IMS communications architecture supports many-to-many connections which is best suited to distributed, time-critical information flow. The IMS allows nodes on the network to produce and consume data on the physical network and provides distributed control of the network. The IMS manages the actual data transfers between nodes on the network. Each node dynamically registers with the IMS and then becomes a producer and/or consumer until deregistration.

The IMS handles the multicasting of all data on the network, thereby allowing virtual links to be setup between the nodes on the network. This architecture is symmetric, robust to changes and failures and is very efficient.

The IMS communications architecture differs significantly from the older *point-to-point* (e.g. TCP) and *client-server* (e.g. RPC) architectures. These architectures suffer from complex connection and error recovery problems as well as single points of failure.

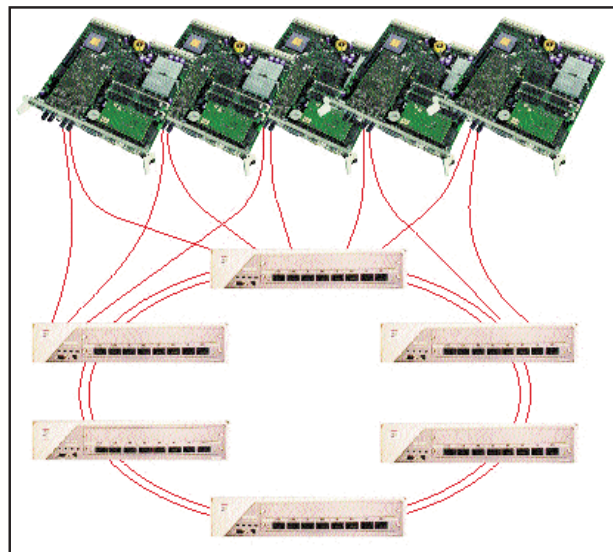

**IMS Dissemination Architecture**

## ► Information Management System

### Functions

#### Transfer Control Data

- Application Interface Services (APIS)
- Xpress Transport Protocol (XTP)
- Internet Protocol (IP)

#### Transfer Bulk Data

- File Transfer Services (FTS)
- User Datagram Protocol (UDP)

#### Network Time Services

- Network Time Protocol (NTP)
- Packet Timestamping

#### Network Management Services

- Built-in Test Services (BITS)
  - LAN Adapters
  - Cable Plant
- Simple Network Management Protocol (SNMP V2.0)
- Graphical Human-Machine Interface
- Operator-Assisted Trouble-Shooting, Maintenance and Reconfiguration

#### Cable Plant

- 62,5 µm / 125 µm Multimode Fibre Cable Plant
- Dual-Redundant Standard
- Quad-Redundant Optional
- Optical Bypass Switches
- Ruggedised COTS Concentrators
- Trunk Coupling Units

### Features

- Critical Virtual Circuit Capability
- Multi-Level Packet Priority
- FDDI Synchronous Mode
  - Synchronous Bandwidth Allocator
  - End Station Support
- Multi-Protocol Support
- SAFENET-Compatible
- Ruggedised FDDI Connectors (ST)

### Performance

- < 950 µs end-to-end latency (< 200 byte messages)
- > 15 Mbits<sup>-1</sup> end-to-end throughput (4 000 byte messages)
- < 250 µs node-to-node synchronisation accuracy (2 σ)