

► Integrated Command and Control System

The Integrated Command and Control System (ICCS) is a hierarchy of Information Technology elements integrated such as to supply commanders and battle troops with command and control data and information to support joint operations in the 21st Century Digital Battlespace.

The ICCS employs a hierarchy of digital radio communications links using standard UHF, VHF and HF radios, digital packet radio modems, as well as personal computer technology, thereby achieving a sophisticated, but flexible, user-friendly, integrated and affordable command and control system.

Functions

The ICCS provides for both vertical and horizontal integration, i.e. lines of command and control between fire units and command centres, as well as between operational units. This aids a Defence Force in early warning of enemy approach. Planning data is transferred digitally between different units thereby reducing the risk of misunderstanding or misinterpretation of data. The units use this information to enhance their own decisions and actions thereby shortening the time from detection to action.

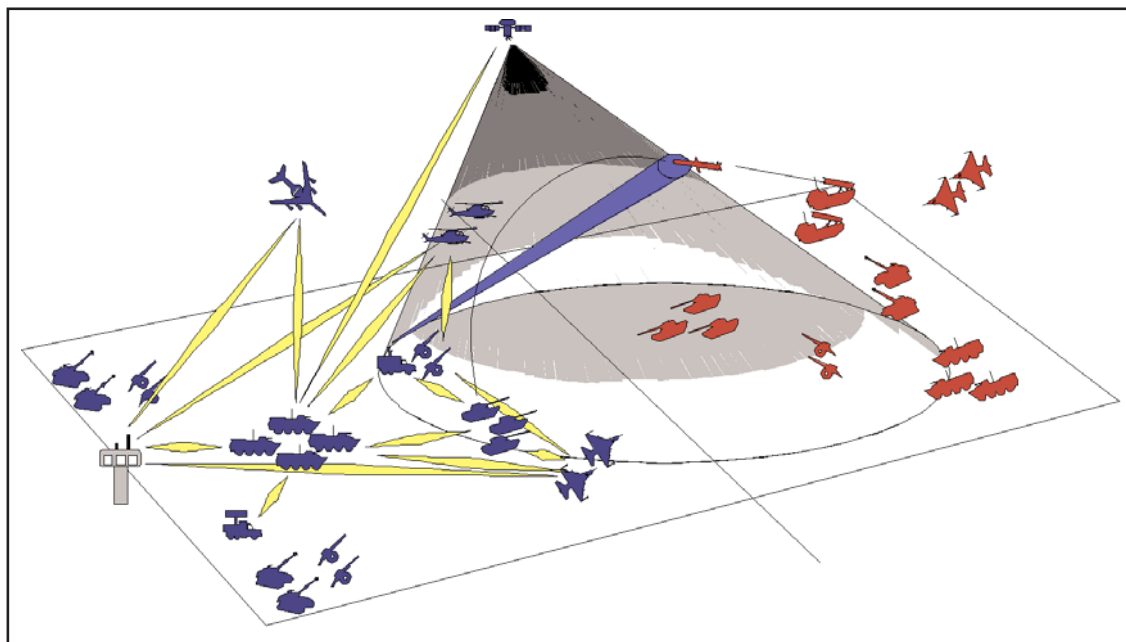

21st Century Digital Battlespace

The commander at area level receives information from sensors, intelligence sources, own troop situation reports, etc. Information from sensors is correlated and fused with information received from other sensors either from different locations or from different types of sensors. These sensors could be Remotely Piloted Vehicles (RPVs), High Altitude Endurance (HAE) Unmanned Aerial Vehicles (UAVs), radars, satellites, etc. The information received is correlated with information received from the intelligence sources such as own agents, diplomatic sources, local population, etc. Information is presented in a graphical, cognitive manner rather than a textual format. The Human-Machine Interfaces (HMIs) utilise multimedia, hypermedia, simulation, animation, multidimensionality, etc. to achieve realistic visualisation of the battlespace.

Relevant data is transferred over the radio network down to the effectors. At each level local data is fused with the data received from the higher level. Data from lower levels is transferred upwards to the area level, then correlated and fused with data available at that level.

► Integrated Command and Control System

Features

- Eliminates Fratricide
- Supports Joint Operations
- Enhances Operational Effectiveness
- Provides Force Multiplication

Architecture

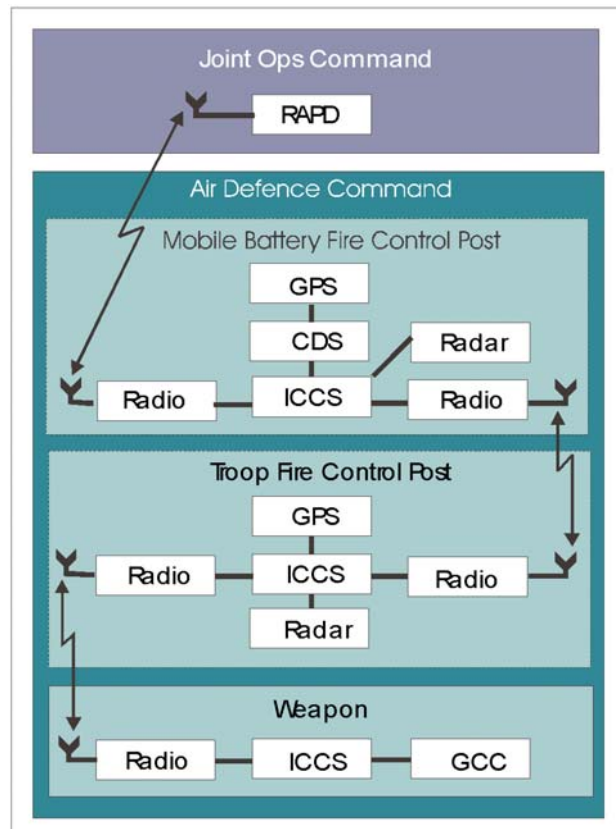

CDS	Control and Display Sub-System	Provides Man-Machine Interface (MMI) for Early and Local Warning Radars. Includes digitised maps
GCC	Gun Controller Console	Provides target bearing and range data to gun commander
GPS	Global Positioning System	Provides navigation and position data for static and mobile units
ICCS	Integrated Command and Control System	Facilitates vertical command and control functionality between various hierarchies of overall air defence system
MBFCP	Mobile Battery Fire Control Post	Provides Early Warning Radar, intermediate air defence picture and battery-level control
RAPD	Remote Area Picture Display	Provides overall air picture from Joint Ops Command
TFCP	Troop Fire Control Post	Provides Local Warning Radar, local air defence picture and platoon-level control
Wpn	Weapon	Engages Target (missile, guns, jammers)