

▶ Video Capture and Compression Adapter

The C²I² Systems Video Capture and Compression Adapter generates a compressed video data stream from a standard RS-170 video source using MPEG4 compression implemented in hardware.

This compressed video data stream can be output directly on one of four high-speed serial output channels or passed to a host computer via the PCI bus.

The Video Compression Adapter is available in the following industry standard compliant formfactors :

- PMC
 - Air-cooled PMC with frontpanel I/O (IEEE Std 1386.1-2001)
 - Conduction-Cooled PMC (CCPMC) with backplane I/O (ANSI/VITA 20-2001)

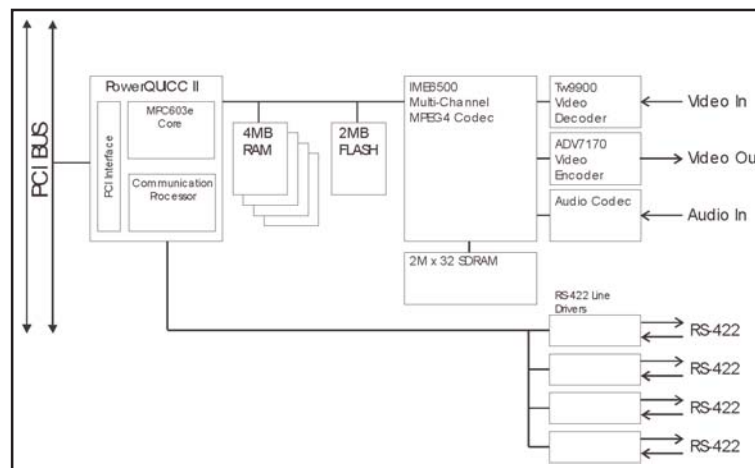

Video Capture and Compression Block Diagram

Architecture

RS-170 (NTSC) Video is decoded by a Techwell TW9900 Video Decoder and the resulting IUT-R BT.656/601 video is compressed by an INTIME IME6500 MPEG4 Codec. The IME6500 features an integrated RISC processor core as well as a DSP core to enable real-time operation, as well as uploadable firmware allowing customised solutions for specific applications.

The MPEG4 data stream is available via the PCI host interface, and can also be transmitted via one of the four RS-422 or RS-485 High-Speed Serial channels which operate at a maximum of 20 Mbit/s each. When not used for video transfer, High-Speed Serial channels are available for data transfer via the PCI host interface. The dedicated Communications Processor contained within the Motorola PowerQUICC II processor ensures that all four High-Speed Channels operate at full capacity while the main processor transfers video.

Features

- Unbalanced 75 ohm or balanced 150 ohm Video I/O
- IME 6500 Multi-Channel MPEG4 Codec with uploadable microcode for high flexibility
- 720 x 480 pixels at 30 fps (NTSC)
- 720 x 576 pixels at 25 fps (PAL)
- User-selectable compression ratio
- Video output for monitoring
- Four 20 Mbit/s High-Speed Serial channels

▶ Video Capture and Compression Adapter

Applications

- Remote Control
- Surveillance and Property Management
- Armoured Fighting Vehicles (AFV)
- Unmanned Aerial Vehicles (UAV)
- Multimedia Broadcast

Specifications	
Bus Interface	32-bit, 33/66 MHz Electrically : PCI Rev.2.2, 3,3 V and 5,0 V signalling
I/O Addresses	Automatically assigned to the slot by PCI Rev. 2.2 Plug-and-Play
EEPROM	EEPROM for board ID (Plug-and-Play) and configuration options
Interrupts	PCI INT A
DMA	Automatic depending on PCI slot
Video Input	Unbalanced : 75 Ohm Balanced : 150 Ohm
Serial I/O Interface	RS-422/485 : TxD, RxD, CLK_IN, CLK_OUT
Termination	100 ohm (individually selectable for each SCC channel)
Bit Rates	Synchronous Mode : 16 Mbit/s Asynchronous Mode : 6,25 Mbit/s
Serial Protocols	- HDLC - SDLC - Async - BiSync
CPU	Motorola PowerQUICC II Integrated PowerPC Microprocessor INTIME IME6500 MPEG4 CODEC
Power	TBD
Software Drivers	Various software drivers offered including for VxWorks, Linux, Windows NT, Windows 2000* and Windows XP* operating systems as standard; others are costed options. (*Standard PC HAL only)
Supporting Software	Sample driver usage software (C/C++ source code)

Characteristics		
Formfactor	Dimensions	Weight
PMC (IEEE Std 1386.1-2001)	149,00 mm x 74,00 mm, conforming to CMC envelope	105 g +/- 10 g
CCPMC (ANSI/VITA 20-2001)	143,65 mm x 74,00 mm, conforming to VITA 20 envelope	95 g +/- 10 g



▶ **Video Capture and Compression Adapter**

Reliability				
MTBF	Figures according to MIL-HDBK-217F, Parts Stress Method			
	Ground, Mobile Naval, Sheltered Airborne, Inhabited Cargo	T _j = 65 C T _j = 60 C T _j = 75 C	T _a = 45 C T _a = 40 C T _a = 55 C	21 700 hrs 35 800 hrs 26 200 hrs

Environmental Specifications			
	Commercial Grade	Industrial Grade	Ruggedised/Conduction-Cooled Grade
Temperature - Operating - Storage	0 C to +55 C -40 C to +85 C	-15 C to +75 C -40 C to +85 C	-30 C to + 85 C -55 C to +125 C
Humidity	0% - 90%	0% - 95%	0% - 95%
Shock	N/A	30 g peak for 11 ms	40 g peak for 11 ms
Vibration - Sine - Random	2 g (peak) 10 Hz to 100 Hz 0,04 g ² /Hz at 15 Hz to 2 kHz	10 g (peak) 5 Hz to 2 kHz 0,1 g ² /Hz at 15 Hz to 2 kHz	10 g (peak) 5 Hz to 2 kHz 0,1 g ² /Hz at 15 Hz to 2 kHz