

► Universal Fibre Hub

The Universal Fibre Hub (UFH) is a multi-format I/O signal concentrator and data redistribution unit. It is highly flexible and configurable and is suitable for use in a wide range of I/O monitoring and control applications. It has exceptional utility in systems which use a wide variety of different and remote sensors and actuators and which need to be connected to a central node more often than not in difficult electromagnetic environments.

The device can be operated in either Standalone or CompactPCI modes of operation and offers an array of analogue and digital I/Os, UART serial I/O channels, USB Host Interfaces, CAN Interfaces and an ATA Interface.

Architecture

The UFH incorporates two processor domains. Digital and analogue I/O processing are off-loaded to an onboard I/O Processor (16-bit RISC microcontroller), while serial I/O, data communications and other higher level functions are handled by the System Processor (32-bit PowerPC microprocessor).

It has an onboard 10/100 Mbit/s Ethernet interface which is configurable for use with either fibre optic or copper media types. The UFH also features an onboard 32-bit 33/66 MHz PMC site, which offers I/O and processing expansion capabilities through the use of a third party PMC adapter. One example of this would be the use of a C²I² Systems Dual Gigabit Ethernet PMC adapter, which provides a dual redundant Gigabit Ethernet link via either fibre optic or copper media.

In most applications the UFH would be used in the Standalone configuration. However, for applications that require enhanced system scalability, the UFH can be used as a PCI Host Controller. In this configuration it can be connected as System Board to a compatible 32-bit CompactPCI backplane and can manage up to five CompactPCI Peripheral Boards.

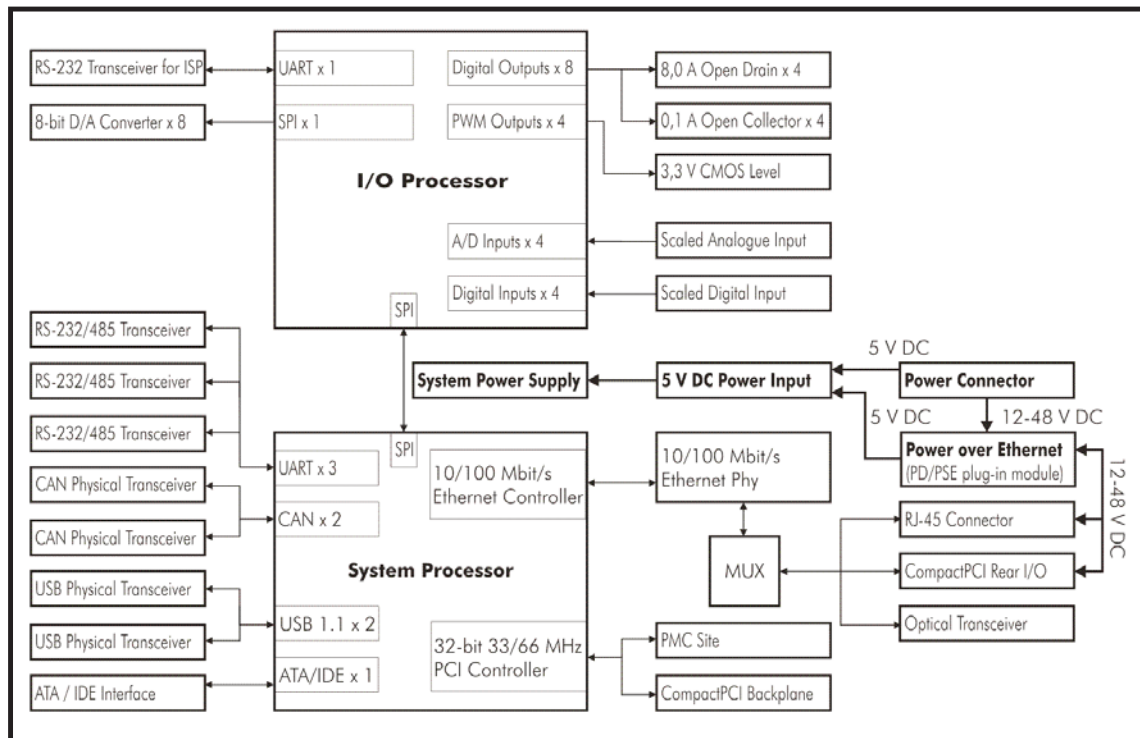

**Universal Fibre Hub
Functional Block Diagram**



► Universal Fibre Hub

Features

- VxWorks and Linux Operating Systems supported
- 32-bit Freescale MPC5200B PowerPC Microprocessor as System Processor
- 16-bit Fujitsu MB96350 Series Microcontroller as I/O Processor
- 32-bit 33/66 MHz PCI : one PMC site and five cPCI Peripherals (on a compatible backplane)
- 32 Mbyte user / application Flash EPROM; 256 Mbyte 132 MHz DDR-SDRAM
- One ATA UDMA4 interface
- Two 1 Mbit/s electrically isolated CAN V2.0 Interfaces
- One 10/100 Mbit/s Ethernet Interface, configurable for fibre or copper I/O media types
- Optional Power over Ethernet (PoE) modules, available as Powered Device (PD) or Power Sourcing Equipment (PSE)
- Three 1 Mbit/s UART Serial I/O Interfaces, configurable as either RS-232 or RS-485
- Two 12 Mbit/s USB V1.1 Host Interfaces (Full Speed, 12 Mbit/s)
- Eight 8-bit D/A Outputs
- Four 10-bit A/D Inputs, also configurable as digital inputs
- Four dedicated Digital Inputs
- Four 8 A Open Drain MOSFET Outputs (with onboard LED indicators)
- Four 100 mA Open Collector BJT Outputs (with onboard LED indicators)
- Four programmable PWM Outputs

Specifications	
System Processor	Freescale MPC5200B Microprocessor, PowerPC e300 core @ 400 MHz
I/O Processor	Fujitsu MB96350 Series Microcontroller
DDR-SDRAM	256 Mbyte @ 132 MHz bus frequency
Flash Memory	32 Mbyte
ATA Interface	ATA UDMA4
LAN Interface	Single Ethernet channel, configurable as either 10/100 Base-T (copper media) or 10/100 Base-Fx (fibre media)
USB Host Interface	Dual USB V1.1 host interfaces, with a maximum bit rate of 12 Mbit/s each
CAN Interface	Dual CAN V2.0 (Part A and B) interfaces, with a maximum bit rate of 1 Mbit/s each
Serial I/O Interface	Three UART serial I/O channels, each configurable for either RS-232 or RS-485 operation, with a maximum bit rate of 1 Mbit/s each
Digital Inputs	Four dedicated digital inputs
Analogue Input:	Four 10-bit analogue to digital inputs (also configurable as digital inputs)
Digital Outputs	Four 100 mA Open Collector BJT outputs Four 8,0 A Open Drain MOSFET outputs
Analogue Output:	Eight 8-bit digital to analogue outputs
PWM Outputs	Four programmable Pulse Width Modulation outputs
PCI Bus Interface	32-bit, 33/66 MHz Electrically : PCI Rev.2.2; 3,3 V signalling Single 32-bit PMC site (with no PMC rear I/O) CompactPCI System Slot Board compatibility, with support for up to 5 cPCI Peripheral Boards



► Universal Fibre Hub

Characteristics	
Physical	Dimensions
	176 mm x 132 mm
	Weight
	230 g
Power	5,0 V DC @ 5,0 A
Software	User defined, running on either VxWorks or Linux operating systems

Reliability			
MTBF	Figures according to MIL-HDBK-217F, Parts Stress Method		
Commercial Grade	Ground, Benign	T _a = 25 C	113 000 hrs
Industrial Grade	Ground, Mobile	T _a = 45 C	22 000 hrs
	Naval, Sheltered	T _a = 40 C	40 000 hrs
	Airborne, Inhabited Cargo	T _a = 55 C	25 000 hrs
Ruggedised Grade	Ground, Mobile	T _a = 45 C	30 000 hrs
	Naval, Sheltered	T _a = 40 C	50 000 hrs
	Airborne, Inhabited Cargo	T _a = 55 C	35 000 hrs

Environmental Specifications			
	Commercial Grade	Industrial Grade	Ruggedised Grade
Temperature - Operating - Storage	0 C to +55 C -40 C to +85 C	-15 C to +75 C -50 C to +85 C	-40 C to +85 C -60 C to +125 C
Humidity	0% to 90%	0% to 95%	0% to 95%
Shock	N/A	30 g peak for 11 ms	30 g peak for 11 ms
Vibration - Sine - Random	2 g (peak) 10 Hz to 100 Hz 0,04 g ² /Hz at 15 Hz to 2 kHz	10 g (peak) 5 Hz to 2 kHz 0,1 g ² /Hz at 15 Hz to 2 kHz	10 g (peak) 5 Hz to 2 kHz 0,1 g ² /Hz at 15 Hz to 2 kHz

Part Selector		
Part Designation	Type	Grade
CCII/UFH/SA/001/COM	Standalone	Commercial
CCII/UFH/CPCI/001/COM	Compact PCI	Commercial
CCII/UFH/SA/001/IND	Standalone	Industrial
CCII/UFH/CPCI/001/IND	Compact PCI	Industrial
CCII/UFH/SA/001/RGD	Standalone	Ruggedised
CCII/UFH/CPCI/001/RGD	Compact PCI	Ruggedised