

► 8-Channel Serial CCPMC Adapter / GPS+7-Channel Serial CCPMC Adapter

The 8-Channel Serial CCPMC (Conduction Cooled PCI Mezzanine Card) Adapter provides eight channels of simultaneous, bidirectional UART (Universal Asynchronous Receiver/Transmitter) serial communications. All channels are individually configurable as RS-232/485 by means of a DIP switch.

A version of the adapter is available with an integrated GPS (Global Positioning Service) receiver, which is known as the GPS + 7-Channel Serial PMC Adapter. This adapter has seven user configurable serial I/O channels with the eighth being dedicated to communication with the onboard GPS receiver.

The adapter is available in a ruggedised, conduction-cooled (CC) formfactor only.

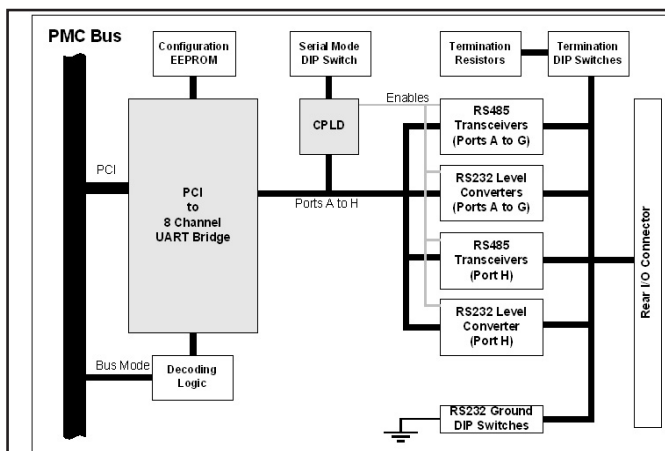

Architecture Block Diagram

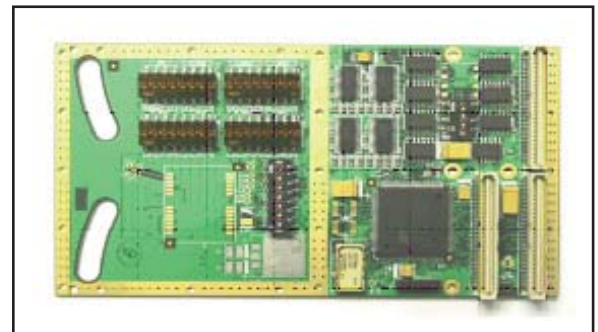

8-Channel Serial CCPMC Adapter

Architecture

The 8-Channel Serial CCPMC Adapter employs a high performance, industry standard 16550 compatible, 8-channel PCI-based UART. Each of the eight UART serial channels are connected to both RS-232 and RS-485 transceivers. The transceivers are enabled / disabled by onboard programmable logic, according to a user specified code which is entered into a configuration DIP (Dual In-line Package) switch.

Features

- Cost-effective option for systems that require a large number of UART compatible serial communication links.
- Allows direct low-level control of the serial communication links.
- The adapter can implement many different combinations of RS-232 and RS-485 communications interfaces simultaneously.

Conduction-Cooling

The 8-Channel Serial CCPMC Adapter conforms to the CCPMC (Conduction-Cooled PCI Mezzanine Card) Standard, namely ANSI/VITA 20-2001.

Applications

- Distributed real-time applications in harsh environments
- Mission-critical applications
- Avionics
- Remote Access Servers



► 8-Channel Serial CCPMC Adapter / GPS+7-Channel Serial CCPMC Adapter

8-Channel Serial CCPMC Adapter Specifications / GPS+7-Channel Serial CCPMC Adapter

Bus Interface	32-bit, 33 MHz PCI-bus Electrically : 3,3 V and 5 V signaling, PCI Rev. 2.3 Mechanically : Single CCPMC formfactor, ANSI/VITA 20-2001
Serial Interface	RS232/422/485 selectable asynchronous transfer with modem control signals. Rear-panel signals : RS232 RxD, TxD, RTS, CTS, DTR, DSR, CD, RI RS422/485 RxD, TxD, RTS, CTS
Bit Rates	User-programmable standard rates up to : RS-232 : 1 Mbps RS-485 : 6,25 Mbps
GPS Receiver	L1 Frequency, C/A Code, 16 Channel
GPS Data Format	NMEA 0183, UBX
DGPS Correction Data Format	RTCM SC-104
GPS Update Rate	4 Hz (max)
GPS Operating Limits	Altitude < 18 000 m, Velocity < 515 ms-1 Either limit may be exceeded, but not both – COCOM (Coordinating Committee on Export Controls) restrictions apply.
I/O Addresses	Automatically assigned to the slot by PCI Rev. 2.3
I/O Options	Rear connector I/O option with various rear connector PMC P14 I/O pin assignments.
Interrupts	PCI INT A
Termination Resistors	100 Ω (switchable) for RS-485
Dimensions	Conduction-cooled : 143,65 mm x 74,00 mm x 9,80 mm (ANSI/VITA 20-2001)
Mass	8-Channel Serial : 65 g ± 10 g GPS + 7-Channel Serial : 75 g ± 10 g
Power Requirement	8-Channel Serial : +5 V at 0,35 A GPS + 7-Channel Serial : +5 V at 0,4 A
MTBF : 8-Channel Serial	Figures according to MIL-HDBK-217F, Parts Stress Method : Ground, Mobile T _j = 65 C T _a = 45 C 37 000 hrs Naval, Sheltered T _j = 60 C T _a = 40 C 77 000 hrs Airborne, Inhabited Cargo T _j = 75 C T _a = 55 C 63 000 hrs
MTBF : GPS +7-Channel Serial	Figures according to MIL-HDBK-217F, Parts Stress Method : Ground, Mobile T _j = 65 C T _a = 45 C 31 000 hrs Naval, Sheltered T _j = 60 C T _a = 40 C 64 000 hrs Airborne, Inhabited Cargo T _j = 75 C T _a = 55 C 46 000 hrs
Software Drivers	The 8-Channel Serial CCPMC interface is compatible with the industry-standard 16550 UART. As such, no specific driver is required for most Operating Systems. VxWorks source code to locate the device in PCI space and obtain a pointer to the UART is supplied as an example. - VxWorks 5.x, 6.x - Linux - Windows 2000, XP, Vista
Supporting Software	Sample driver usage software (C/C++ source code)
Options	Port software drivers to various other operating systems on request

Environmental Specifications

	Commercial	Industrial	Ruggedised/Conduction-Cooled
Temperature			
- Operating	0 C to +55 C	-15 C to +75 C	-40 C to + 85 C
- Storage	-40 C to +85 C	-40 C to +85 C	-55 C to +125 C
Humidity	0% to 90%	0% to 95%	0% to 95%
Shock	N/A	30 g peak for 11 ms	40 g peak for 11 ms
Vibration			
- Sine	2 g (peak) 10 Hz to 100 Hz	10 g (peak) 5 Hz to 2 kHz	10 g (peak) 5 Hz to 2 kHz
- Random	0,04 g ² /Hz at 15 Hz to 2 kHz	0,1 g ² /Hz at 15 Hz to 2 kHz	0,1 g ² /Hz at 15 Hz to 2 kHz

Designations

CCII/SIO/PMC/UART8/BP/CC/	Ruggedised, Conduction-Cooled	Backplane I/O	RS232/485
CCII/SIO/PMC/GPS/BP/CC/	Ruggedised, Conduction-Cooled	Backplane I/O	RS232/485