

► 2-Channel UART Serial I/O PMC Adapter

The 2-Channel UART Serial I/O PMC (PCI Mezzanine Card) Adapter provides two RS232 channels of simultaneous, bi-directional UART (Universal Asynchronous Receiver/Transmitter) serial communications. The adapter is available in both conduction-cooled (CC) and air-cooled versions : ruggedised, industrial and commercial.

Architecture

The 2-Channel UART Serial I/O PMC Adapter employs a PCI-based dual-channel, high performance, industry standard 16550 compatible UART.

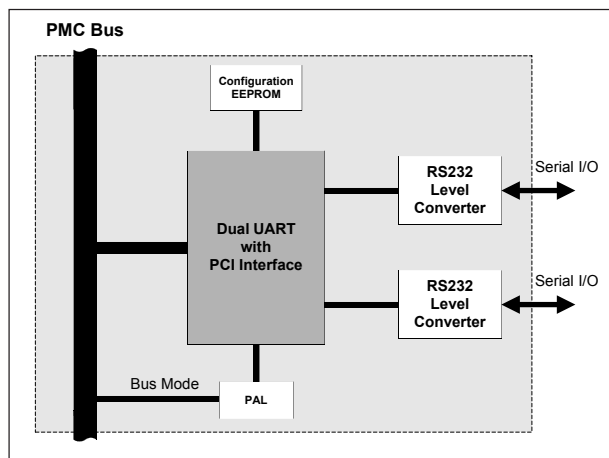

Architecture Block Diagram

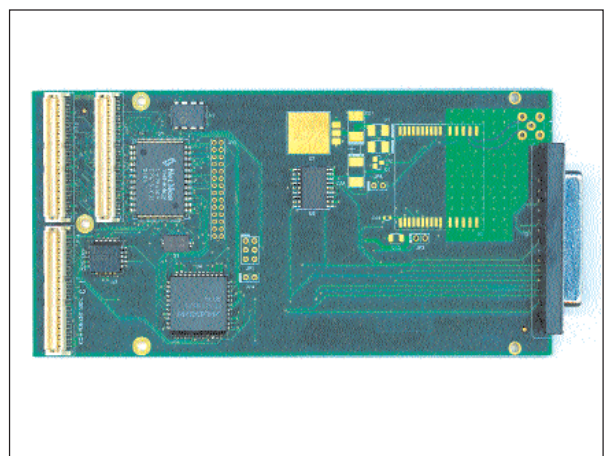

2-Channel UART Serial I/O PMC Adapter

Features

- Minimal option for low-cost systems or systems that require more UART-compatible serial communication links than offered by the host.
- Allows direct low-level control of the serial communication links.

Conduction-Cooling

The conduction-cooled 2-Channel UART Serial I/O PMC Adapter conforms to the CCPMC (Conduction-Cooled PCI Mezzanine Card) Standard, namely ANSI/VITA 20-2001.

Applications

- Distributed applications in harsh environments
- Avionics
- Mission-critical applications



► 2-Channel UART Serial I/O PMC Adapter

2-Channel UART Serial I/O PMC and CCPMC Adapter Specifications

Bus Interface	32-bit, 33 MHz PCI-bus Electrically : 5 V signaling, PCI Rev. 2.2 Mechanically : Single CMC formfactor IEEE P1386-2001
Serial Channels	2 x RS232 channels
Serial Interface	Front and Rear-panel RS232 Signals : Rx/D, Tx/D, RTS, CTS, DTR, DSR, CD, RI
Bit Rates	User-programmable standard rates up to 115,2 kbps
I/O Addresses	Automatic assigned to the slot by PCI Rev. 2.2 Plug-and-Play
I/O Options	Front-panel and rear connector I/O options with various rear connector PMC Jn4 I/O pin assignments. Conduction-cooled version has rear connector I/O only.
Interrupts	PCI INT A
Dimensions	Air-cooled : 149,00 mm x 74,00 mm with envelope according to CMC specification Conduction-cooled : 143,65 mm x 74,00 mm (VITA 20) with envelope according to VITA 20 specification Outside Dimensions : 160,00 mm x 75,00 mm x 15,00 mm
Mass	50 g ± 10 g
Power Requirement	+5 V at 0,25 A
MTBF	Figures according to MIL-HDBK-217F, Parts Stress Method : Ground, Mobile T _j = 65 C T _a = 45 C 74 000 hrs Naval, Sheltered T _j = 60 C T _a = 40 C 105 000 hrs Airborne, Inhabited Cargo T _j = 75 C T _a = 55 C 81 000 hrs
Software Drivers	The 2-Channel UART Serial I/O PMC interface is compatible with the industry-standard 16550 UART. As such, no specific driver is required for most Operating Systems. VxWorks source code to locate the device in PCI space and obtain a pointer to the UART is supplied as an example. • VxWorks - For Linux kernel V2.4.x, tested with Red hat 7.1 and 8.0.
Supporting Software	Sample driver usage software (C/C++ source code)
Options	Port software drivers to various other operating systems on request.

Environmental Specifications

	Commercial	Industrial	Ruggedised/Conduction-Cooled
Temperature			
- Operating	0 C to +55 C	-15 C to +75 C	-40 C to + 85 C
- Storage	-40 C to +85 C	-40 C to +85 C	-55 C to +125 C
Humidity	0% to 90%	0% to 95%	0% to 95%
Shock	N/A	30 g peak for 11 ms	40 g peak for 11 ms
Vibration			
- Sine	2 g (peak) 10 Hz to 100 Hz	10 g (peak) 5 Hz to 2 kHz	10 g (peak) 5 Hz to 2 kHz
- Random	0,04 g ² /Hz at 15 Hz to 2 kHz	0,1 g ² /Hz at 15 Hz to 2 kHz	0,1 g ² /Hz at 15 Hz to 2 kHz

Designations

CCII/SIO/PMC/2P/FP/COM	Commercial	Front-panel or Backplane I/O	RS232
CCII/SIO/PMC/2P/FP/IND	Industrial	Front-panel or Backplane I/O	RS232
CCII/SIO/PMC/2P/FP/RGD	Ruggedised	Front-panel or Backplane I/O	RS232
CCII/SIO/PMC/2P/BP/CC	Conduction-Cooled	Backplane I/O	RS232